

March 2018

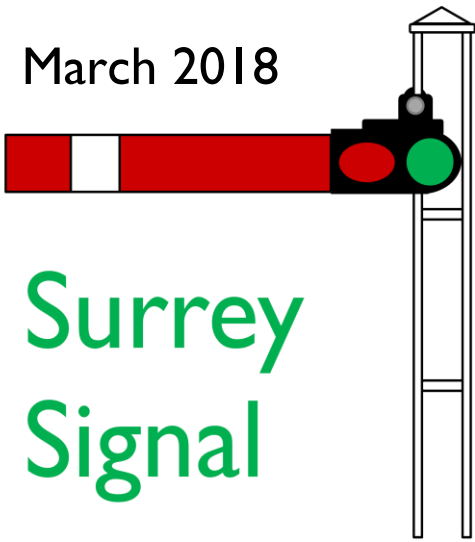

# Surrey Signal

An occasional newsletter  
for the GIMRA Surrey Group

*Published every 18 months whether you want it or not*

## Royal Holloway Science Festival

We return to the RHUL Science festival this year on

**Saturday 10<sup>th</sup> March 2018**



Regulars will know that the event was suspended in 2017 to allow us to finish off a massive program of building works.

This year we are back in the Victorian boiler house (above). The current heating plant only occupies a small part of the original space, so the rest has recently been lightly renovated, and makes a terrific industrial setting for the Surrey Oval.

There is a lovely new café in the courtyard which should help bring the public into our display. I have already had several enquiries from previous visitors anxious to know that we'll be running again this year, so I have high hopes for a strong turnout.



## Set up and running times

We have access from 15.00 on Friday 9<sup>th</sup> for setup. We have to crank the seating back, and that requires somebody from our Estates department, so there may be a delay before we can start construction. We can then run as we fancy, though I'd like to be away by 19.00.

On Saturday I will be present from 08.00am. The public nominally arrive at 10.00am, but on previous experience they start trickling in not long after 9.00 so I suggest we start running at 9.00am. The show closes at 16.00

There is another event following us in the evening, so we need to be able to knock down and clear the space by 17.30. I'd very much appreciate everybody's cooperation in getting this done: on previous experience it shouldn't be a problem.

## Directions, drop off and parking

The College postcode is TW20 0EX. You enter the campus from the A30 as indicated bottom left on the map on the next page. Once through the gate drive down to the main building and then follow the perimeter road to the left. As the road drops away, you'll see the chimneys on your left. For drop off, please take the left turn, park up and bring your things in. Please then re-park in the large car park at the bottom of the hill shown at top right of the map – this is College car park 4.

We are expecting 4-6,000 visitors on campus, so if you are coming after 9.30 you may be redirected to another car park. If you let the student ambassadors know that you are with the steam engine display in the boiler house they should let you through. If all else



fails, mention Simona Lam (who is the organiser) or Prof Adrian Johnstone (who is me).

Peter Jackman is towing the trailer in on Friday and James Mander is taking it back to GMES on Saturday. I have special dispensation to park the trailer itself in the courtyard overnight and during Saturday to aid a quick getaway.

Piers Plummer will once again be joining us with a display of Babbage-related computational devices, including a complete four-column by six-digit difference engine run by Stewart No. 9 engine which will be in steam (now that James has kindly certificated the boiler). Preview at

[www.youtube.com/watch?v=t8aYkow-Fv8](http://www.youtube.com/watch?v=t8aYkow-Fv8)

## IWO – Ian’s Wonderful Outings

Ian Russell has thrown himself into finding venues for the Oval, in particular with a view to public running days where we can cover the cost of hall hire and public liability insurance by charging the public an entry fee.

I’ll admit to being pretty sceptical as to whether we’d generate much interest. Nevertheless, early one Saturday morning in November 2016 Ian and I were shifting chairs and awaiting the trailer at the United Reform Church hall in Dorking. The church’s Sunday School had pasted up ‘Why are we here’ on the back wall, and I felt that was a jolly good question...

We set to as usual, and soon had a track up and running with please-don’t-burn-your-fingers signs up; and engines started to circulate. We’d have a good day, even if nobody came.

Come 10.00, and the doors opened and something rather magical happened: a continuous stream of shoppers, young families and what I can only describe as superannuated train spotters came through the door, munched cake and watched the trains. In total we had nearly 100 adult visitors, and covered our costs nicely.

We’ve since had two return visits in Spring and Autumn 2017, and have seen both plenty of repeat business and, perhaps, a slight drop-off in overall numbers. With that in mind, in 2018 we shall have one autumn run in Dorking, and a run in May at a new venue-**Cranleigh Village Hall on Saturday 26<sup>th</sup> May.**



This venue is a little more expensive, but is right in the heart of the ‘village’ (it’s a small town really) and immediately adjacent to a supermarket, so again we’re hoping for significant passing trade. The hall is a little more spacious than Dorking though the Oval will have to be set up at an angle.

We make quite a lot of money selling cakes at these meetings, and I’d like to thank everybody who has baked for us during the year and, of course, to our kitchen teams who did such sterling work.

# If you build it, they will come

## Scenes at Dorking from Yves



The public presence: steady but never too busy.



Mike Bland and sundry luminaries doing a fine job of extracting entry monies from the good folk of Dorking.

Ian's scenic additions to the Oval include rusty wheels and old track; Elizabeth's chocolate train behind the signal box





## A visit to Belmond British Pullman

*Richard Burkett*

A few weeks ago I was very lucky to visit the Belmond British Pullman maintenance works and ride the footplate of the Royal Scot (46100).

British Pullman share their maintenance depot with the Gatwick Express, but the site dates back a great deal longer: it was originally called Stewarts Lane which is not far from Waterloo.

The British Pullman facilities comprise the older buildings, sheds and workshops with many signs showing VSOE (Venice Simplon Orient Express) origins, and this was clearly the depot where VSOE trains were prepared.

The facilities for the Gatwick Express are very modern, comprising mostly carriage sheds and workshops. I went through every one of Belmond's current 11 Pullman cars, and on the Saturday morning I visited they were preparing 10 cars for the Surrey Hills Excursion in the afternoon.

Each car is styled differently, but they are all beautiful examples of luxurious interiors from the 1920's and 30's. The kitchen in each carriage is generally pretty small, and it is amazing to think of how they prepare and serve a few hundred meals from them whilst in motion.

Belmond are still interested in finding Pullman cars: I saw one in dilapidated condition which has just been "recovered" and over the next two years will be restored to magnificence to join the others. The highlight of the visit was getting on to the foot plate of Royal Scot and pulling the whistle to signal the start of a test run up and down one short stretch of track.

Needless to say all was perfect, and after this short trial the engine went away to couple up with the selected coaches and then off to Victoria to pick up passengers. So, a fascinating insight into the behind the scenes of luxury steam hauled trains !



## A valve gear protection shield for the Aster Bulleid *Peter Jackman*

I purchased my Aster BR liveried BB class kit from new in 2012. In fact I believe this was the last Winston Churchill kit available. Subsequently I started and completed the build in 2015 as 34064, Fighter Command. While building I fitted radio control to the regulator, blower and reverser. This is much easier to do during the build than as a later conversion. Various members have asked me to describe this particular RC installation and I plan to do so in a subsequent article.

### Valve gear motion vulnerability

Several successful and enjoyable running sessions with the completed loco took place. During one subsequent run however it suddenly stopped and could not be persuaded to continue. I suspected a screw or pivot pin had come loose somewhere although I had fastidiously used Loctite 222 on all screwed fasteners.

Back home on the bench I discovered severe damage to the centre valve radius rod, (Aster part 3-4) and Valve Guide Link (3-12). Both these parts were bent and the radius rod slot had opened up and twisted. What was not so obvious was the root cause of this damage.

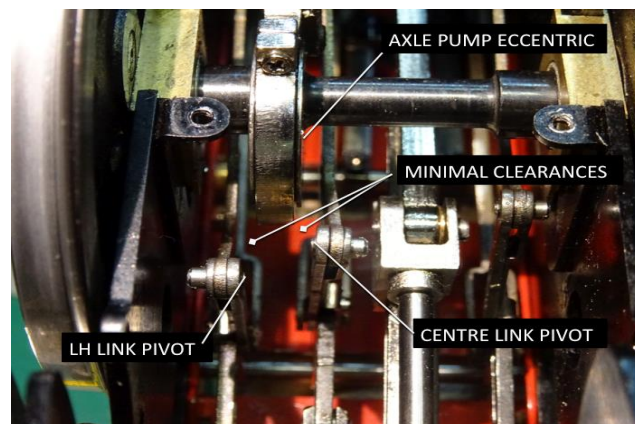

After careful examination of the motion and its movement with the loco inverted I concluded that the pivoting joint at the forward end of both the centre and LH union links (3-14) could, with a little side play, collide with the axle pump eccentric. I am certain this happened with the centre link pivot on my loco. Unfortunately, just re-positioning the eccentric axially on the front axle does not ensure its avoidance, as the distance between the centre and LH links is not sufficient for the eccentric to clear both links reliably when allowing for link side play. This picture shows the damaged parts.



I believe that most owners of these locos don't use the reverse gear much and that if left in forward gear the likelihood of experiencing a similar accident is minimised but not eliminated. As I use my RC reversing fairly frequently this is more likely for me.

### Protecting the motion from collision

I did consider making replacement parts but the radius rod actually comes as a pre-pivoted assembly and although I quite fancied the engineering challenge decided that life is too short and I purchased the two replacement parts from Aster Hobbies. I did decide however that I would not fit these without also finding a way to guard against a similar parts collision in future.

After several hours of taking measurements and developing a CAD model I decided that two vertical shields of PTFE sheet one placed each side of the axle pump eccentric should do the trick. This is a 3d CAD view of the designed shields and their brass plate support.

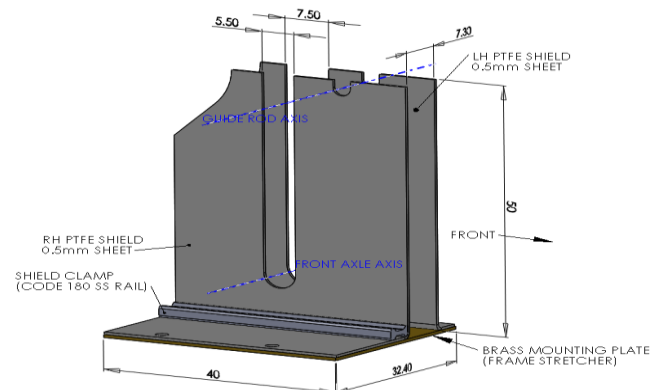

To enable me to physically check dimensions and provide templates for the sheet parts I exported data from the CAD model and 3d printed some flat templates from PLA.

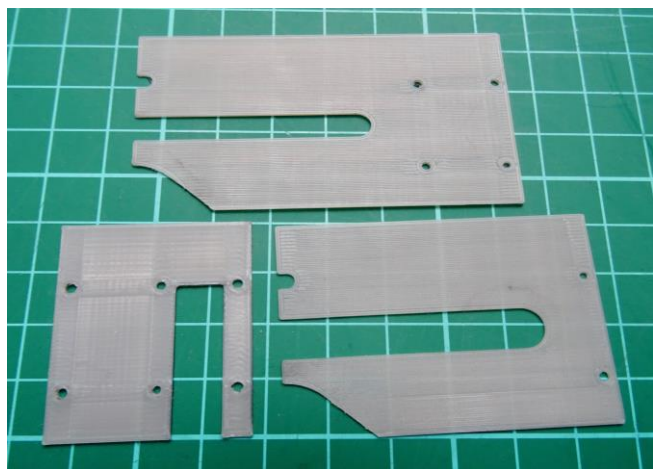

### The motion shields

The PTFE shields were made from 0.5mm thick sheet and a support plate/frame stretcher from 0.7mm brass. The bends in the PTFE sheet resist taking on a permanent set and the material needs to be

mechanically fastened in place. This was achieved for the RH shield with a clamping bar made from a length of code 180 stainless rail. All is held in place with loctited M2 screws. The whole assembly was fastened underneath the loco and the front axle box retainers by using the existing retainer screws holes. This shows the shield assembly prior to mounting...

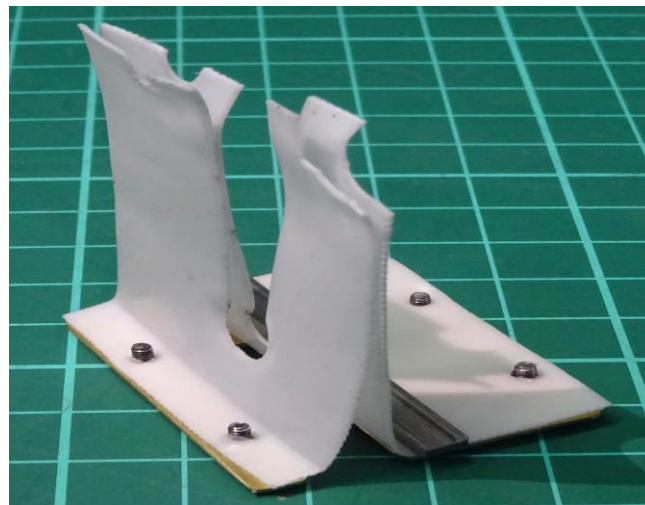

And here is the completed shield assembly in place.

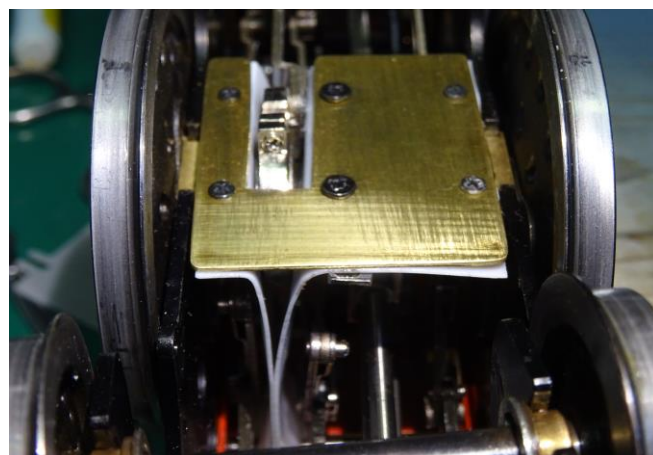

### Testing

At the time of writing, the loco has been run in steam on a rolling road with frequent stopping and operation of the reverser by RC. The shields appear to do their job very well and do not add any perceived friction to the motion. The positions between the axle pump eccentric and the union links completely prevents their interference even with link side play. Track running will be resumed soon to confirm this in service. Should any one wish to make similar shields, I can provide dimensioned part drawings if useful.



## Pauline Ann Hulse

### 1941-2017

Pauline Hulse, founder member of the G1MRA Surrey Group passed away in early February 2017 after treatment for cancer. Pauline asked that we run trains in her memory, and so after the very well-attended funeral, we returned to Bookham for a wake that was also a G1MRA get-together, with a strong emphasis on the Great Western as Pauline would have wanted. There was standing room only in the chapel, and a crowd at Martin's; people brought together to celebrate a life lived well.

Pauline studied Chemistry at King's College London between 1960 and 1963 where she met Martin. They married in 1966, worked in London and abroad, and joined G1MRA in the 1980's after returning to the UK from Frankfurt. They drove G1 trains at many exhibitions, built their own track at the house in East Horsley and attended get-togethers and exhibitions all over the UK and abroad in France, Belgium and even The Isle of Man.

Pauline was the only lady to run trains on the famous IMREX Easter Exhibition layout. She also drove some of the available engines at the Sutton Model Engineering Club on the larger gauge lines, and drove full size steam engine including Cadbury's Bournville Tank #1 and the GWR King Edward II.

In 1990 Pauline left BP and decided to devote herself to archaeology, local history and other pursuits. She was a pillar of the Surrey Archaeological Society and involved with many field surveys and digs. Martin joined her in retirement in 1997 which meant they could do more things together. They edited the G1MRA Newsletter & Journal for 5 years, as well as serving on the G1MRA Committee; created the Pictorial Record of Lovelace House in East Horsley; coordinated mapping the graveyard at St. Mary's church West Horsley as a U3A project; and worked on the Lovelace Bridges project.

The Surrey Group was started in the summer of 1999 by Martin and Pauline who wanted to help develop the local groups. They invited all of the Surrey members they knew to a GTG, including Alan England, Art Walker, Bob Symes, Mike Bland, Peter Howland, Peter Trinder and Peter McCabe. The group continues to go from strength to strength. Pauline was involved in the inaugural runs on the Surrey Oval portable track, and continued to attend and host meetings through 2016.

In 2013 they 'downsized' to Bookham, which in practice meant that they moved to a bigger property in a smaller garden. Martin built a simpler railway for them to play trains on.

In 2016, despite a second breast cancer, they celebrated their golden wedding anniversary in the Greek Cyclades islands and spent Christmas in Turin.

We shall all miss Pauline for her company, for her clarity of thought and for her determined support for the things she held dear; not least the Great Western Railway.

## Martin's GTG, March 2017

Pictures by Matt Scruton



Liz, Adrian and Mike steam up..

Mike runs Mallard...

Martin fettles his 9F

Ken's Standard 5



## Modelling news



This is Yves' magnificent new coach under construction in January 2017. It is now finished, and he has a complete train running, including some of Alan's old wagon kits, now made up beautifully. I'm very pleased to see that the J38 is still in brass – hopefully this will start a new trend and people will one day stop asking if I'm going to paint my Q1...



Elsewhere, Liz and I are building up the ex\_Alان England J38 that I bought. The chassis is running fairly well on air, and we're turning to soldering the tender and bodywork. Matt sent me this super photo of the cab from his J38 after he soldered it all together. I doubt I'll get anywhere near that quality of workmanship but very I'm grateful for his advice...



One other thing – Garden Rail December 2017 had two articles from us in it: one a version of my Ashford High Line web piece, and the other from Matt on weathering.





# Taming the Aster pannier – without Radio Control

*James Mander*

I can still remember trips to Didcot steam museum as a toddler, being fascinated by the unique lines of a GW Pannier tank and in addition to this, its depiction in the Rev Awdry stories of course! As the maid of all work they were found all over the railway network and even I've even heard the most anti-GW fans describe them as "cute". So, when I saw a second hand Aster example become available, I needed to have it; I had just bought my first Gauge 1 loco!



Those of you that own one of these Aster designed locos or have seen one running will know their high speed performance can often put a Bullied Pacific to shame. Although new to Gauge 1, I have owned and operated manually controlled garden gauge live steam locos since my teens so, it was obvious that this, borderline uncontrollable, performance was not normal. I wanted the engine to potter along at a scale speed with a pick-up freight or an auto-coach.

Initially, I systematically experimented with a range of regulator settings, steam pressures, boiler water levels and even tried running with the blower open in order to keep the steam pressure constant, but the loco would still only run at two speeds- stopped or scalded cat with the lightest touch of the controls.

So, I set about further investigation in order to manage its performance. From previous experience I had a good idea of where the problems might lie, so I tackled the easy to solve problems first and evaluated their performance first before moving onto a more complex modification.

## **Lubricator**

On review of the instructions and build manual which were provided with the loco, it was intriguing to see such a large steam oil reservoir for the lubricator on a small engine. When running it, it soon became apparent why; it was required to feed its ferocious consumption of steam oil, coating the loco, rolling stock and innocent bystanders in the stuff. Looking at

the chimney, the blast pipe could be seen to be pumping steam out oil, hindering the exhaust flow from the cylinders. At times the engine would run very jerkily as it hydraulically locked momentarily on oil.

Model steam locomotives do not need vast quantities of steam oil mixed with the steam. The tiniest trace of it at the chimney is sufficient to demonstrate proper lubrication, any more than this is wasteful. It was evident that in standard trim that this flow was excessive.

On this loco the lubricator is of the "dead leg" type which, consists of a reservoir mounted in the left-hand side tank. It is teed into the live steam feed before the steam chest via a short length of 1/16" diameter copper pipe. Presumably to aid assembly of the loco, there is a union part way in this pipe run. Disassembly revealed that this union was sealed with O rings, so it was easy to separate the connection.

The pipe is full bore throughout its length, so there is no control over the oil flowing to the cylinders. Previous experience has shown that an orifice of 0.2 mm is correct for garden gauge locos. I could have made an orifice to insert into the pipe, but I instead used a method to reduce the diameter of the copper pipe at its end described by Keith Bucklitch. This is where you anneal the pipe and swage it down by careful hammering and rotating with a drill, of the desired inside diameter, inserted in the pipe bore. I could foresee that I would destroy my 0.2 mm drill with an errant strike of the hammer, so instead found a strand from my wire brush was 0.2 mm and with such a quantity I could treat them as a consumable in the process!

With the pipe inside diameter reduced to 0.2mm and the loco reassembled, it greatly reduced the oil consumption and stopped the loco hydraulically locking. However, it was still very difficult to control. The slightest angular movement of the regulator was resultant in a significant change of speed.

## **Regulator cone**

The sensitivity of the regulator indicated that it needed modification. The regulator is of the needle valve type and the valve is located at the smokebox tubeplate end of the boiler. Consequently the regulator rod is at least the length of the boiler and it's withdrawal necessitates complete removal of the bunker and cab.

Once the regulator shaft had been removed it revealed that the valve cone had a 90 degree included angle. This blunt cone was giving the Boolean operational characteristics of the valve. The cone was re-machined to give a finer 60 degree included angle. Be careful to ensure the regulator rod is completely concentric in your chuck (either a 4 jaw or very good 3

jaw) with a DTI before turning it to the new angle. Failure to do so may give a crooked new cone resultant from run out in the chuck and the valve will not seal! – Bad language ensues.

The result was an engine which was much more manageable, it's speed could be predictably set without 4 regulator corrections in a 1 m stretch of track as before. However, although I could now finely control the loco, in attempt to get it running slowly and it would on a straight level track, but the slightest change in conditions would cause it to stall. I'd have it plodding round at a scale 30mph for a couple of laps, but it wouldn't perform consistently. On attempting to get the loco to restart, either by nudging it or applying more regulator, I found it was very reluctant to start, as if steam wasn't being admitted to the cylinders. It either needed a large increment in regulator or an extended push to get it restarted. Further investigation into the valves and cylinders was required.

### **Steam Lap, cut off and valve timing.**

The valve timing of the loco had always been spot on and even. Its exhaust had always been very soft though, so I wondered if the reluctance to run slowly or start a train from rest was due to insufficient steam admission to the cylinders. Referring to the technical data for the loco, I noticed the slide valves had been designed with 1.2 mm of steam lap. This equated to about 25 degrees past either dead centre before steam was being admitted. Steam was cut off at about 20 degrees before the end of the stroke. A set up which is fantastic for higher speed economy running, but at low speed the engine was being strangled. The engine only has 10 mm bore cylinders, so needs all the steam delivery it can get for smooth running.

The next procedure will have the purists of Gauge 1 model engineering reduced to tears, but remember what my objectives are here; to get a locomotive to run consistency at low speed. Something had to be done to remove this excessive steam lap and cut off. In my opinion, steam economy is not of concern in garden gauge model engineering, a steady running loco is. In any case these engines are never short of steam!

Checking the dimensions of the cylinder steam ports against the slide valve as a sanity check, I confirmed the figure stated in the instructions was correct. I urge any other applying these modifications to do likewise to ensure you don't end up with both cylinder ports open at the same time! I found that removing 1 mm from each end of the valve would be correct, leaving 0.5 mm at each end to ensure sufficient sealing when the valve was in its mid-position. So now, steam would be admitted to the cylinder almost immediately the valve moved.

The valves are controlled by slip eccentric valve gear. The stops in either forward or reverse are set and not adjustable by the user, presumably by Aster to prevent people like me from fiddling with their masterpiece! Changing the length of the valves will clearly send the valve events into complete turmoil by advancing everything significantly. Steam ports were being opened much too early and closing much too late. The slip eccentric stops needed to be retarded in both forward and reverse directions by some 10 degrees.

This was done by carefully removing material from the eccentric stops on the crank axle using the mill. Patience is key here; clearly removing too much material is detrimental to the job. Although I had calculated how much material needed removing, as 1.5 mm off each stop I regularly checked it against the loco. I'd urge others to do likewise.



The valves would now admit steam just after each dead centre and close just before. Steam was being admitted for as much of the piston stroke as possible. Out on the track the engine would run much more happily at lower speeds and had a terrific bark to the exhaust.

### **Piston Rings**

Referring again to the now invaluable Aster build manual, I saw each piston was fitted with two square section PTFE piston rings. Their design is not dissimilar to an internal combustion piston ring, with a diagonal

split through its section. The only difference to an IC piston ring is that there was no gap at its ends when installed in the bore. For me this was a first time I'd seen this type of installation on a model steam engine, usually used to more conventional silicone O-rings. Knowing that PTFE has a very high coefficient of linear thermal expansion (~140% greater than brass of the cylinders and pistons) and without a ring gap, the smallest amount of PTFE growth would force the ring hard against the bore. This would be appropriate if the application was to seal 300psi, but on our model locomotives we're dealing with <20psi in the steam chest. The friction from the piston rings was robbing power from the engine at low speeds, which I wanted for smooth running.

I elected to fit the loco with new pistons with more conventional O-rings. I have found red silicone O-rings to be the most suitable and only one is required per piston. I recommend ignoring commercial manufacturers' instructions on O-ring to bore compression (or pinch), remember we're only sealing very low pressures here, and have found 5thou additional to bore diameter is sufficient for our sized bores. This loco has 10 mm bores, so I used 8 mm Internal Diameter x 1mm Cross Section O-rings are available from Polymax. With this size of O-ring, to obtain the desired pinch, the O-ring groove needs to be 8.13 mm OD. Additionally, the ring needs clearance to roll in the groove, so as the piston travels the bore, the ring does not bind at the reversing point – I have found that 1.5x O-ring cross section works well for this. Simply use your parting off tool to generate the groove and clean off any burrs with a small needle file and fine wet and dry.



I reused the original piston rods from the engine, (which are 3 mm diameter stainless steel should you opt to replace the assembly en-bloc), so first had to remove the old piston. I found that the piston rod was

threaded into the piston, but also swaged over to stop it coming loose. To remove this swage without damage, I chucked the piston rod in the 4-jaw chuck (my 3 jaw isn't accurate enough), indicated its centre with a DTI and used a light touch with the centre drill to remove the swage. The piston could then be removed from the rod. Surprisingly Aster appear to have used a 6BA thread to retain the pistons, the remainder of the loco is entirely metric! With the new pistons made with the O ring grooves as above, I retained them onto the threads of the piston rods with a smear of Loctite 243. Swaging the rods over seemed a little excessive for a model steam loco. This picture shows the original assembly with the old piston.

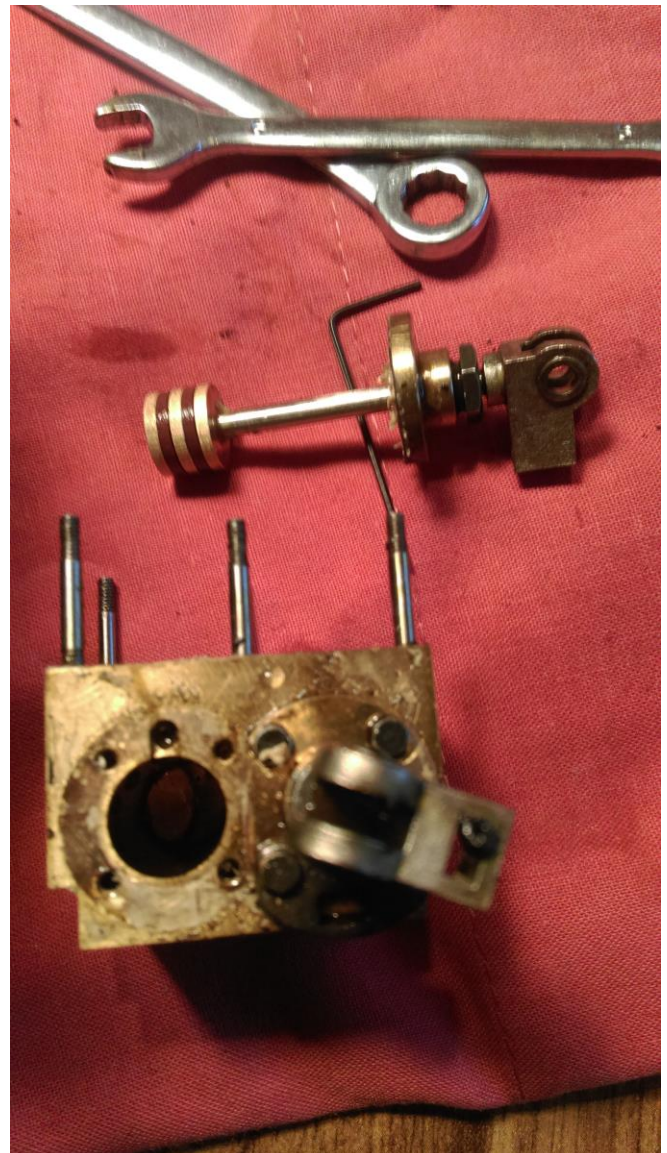

With all of the above modifications complete, the loco was now predictably controllable and would plod round at low speed with a small train without stalling. There is room between the frames to fit a cylinder block with 1/2" bores, not to increase the power of the loco, but to further improve its low speed performance. I may well investigate this in future.

Apparently, some say he waddled, but with a little bit of fettling, this pannier can really be a useful engine.

# George William Henry Swallow

## 1936-2017

George Swallow died in December 2017 after a short illness. Most members first became aware that he was unwell at this year's AGM in Godmanchester, when the committee announced that George had had to relinquish his role as Examiner of the Association's Accounts. Eighty years of good health followed by a short illness is in some ways a blessing, but the suddenness of George's absence is still shocking.

St Barnabas in Ranmore in was packed with nearly 200 people for the funeral reflecting George's wide interests and participation in so many crafts: music, musical instrument making, bell ringing, live steam in the 16mm, Gauge 1 and 3 1/2" traditions and woodworking to the highest standards.

The eulogy reminded us that George was *a man who could never do nothing for long*: he was fascinated by the making of things and wanted to try techniques for himself, even at one time making shirts for himself just to understand the process. This naturally led him to work from first principles, or at least off-drawing: kits were not for him. His scratch-built efforts were rarely seen on the track, and he was rather disparaging about his own skills which is a little surprising - his 3 1/2" Tich chassis is a beautiful piece of work. Perhaps if you are an instrument maker, where aesthetics rule, you might hesitate to run some of our efforts where 'Good enough for Gauge 1' is the motto. He was kind enough never to challenge those of us who choose to run unpainted engines in public.

George was always ready too to encourage the rest of us in our scratch building efforts.

George was born and brought up in Hull. The northern cadences that remained in his voice somehow suited the man - George cultivated a wry and understated humour that underpinned sometimes quite direct opinions but with an openness to debate.

Only three at the outbreak of war, George's early memories were of nights in the air raid shelter and a year in hospital with TB during which his parents were only allowed weekly visits. Nevertheless, George had a successful school career leaving grammar school to pursue accountancy, though not before his mother had declined to allow him to start an engineering apprenticeship. He rose to the Head Office of Sainsbury's before retiring in 2000. Subsequently he supported numerous organisations (including G1MRA) with his financial skills and experience.

George was a great joiner-in, being a member of Sutton MEC, Guildford MES, the 16mm society and, of course, G1MRA where he is listed as a new member in the July 1982 NL&J. In 2005 he joined the committee as treasurer (and at times as meetings organiser) up until 2011; after that he continued to provide professional advice to the association on financial matters, and also to the Surrey Group when we were setting up our bank account and constitution. He worked with us to construct our portable layout, and worked tirelessly at our public outings: last February he spent an entire Saturday washing up rather than running engines. He wrote occasionally for us too: his 'Mug's Corner' piece in NL&J 220 on fitting an SECR C-class tender with its edging is brief and well-illustrated, as befits George's direct approach to engineering challenges.

George has his own kind of memorial within St Barnabas. Instances of his carpentry and cabinet making skills are spread throughout the church: the tall Paschal candle stick, the west-facing altar, carved mahogany boxes for the bell ringers to stand on and many other items even down to the switch box covers. He joins the host of artists and artisans that, down the ages, have let their unsigned work speak quietly for itself. We shall miss him.



# Who was 'Guard Greenly'

## John Mair

*Some of you have heard my talk on The History and Technology of Gauge 1, and you might know that I spend a bit of time talking about Henry Greenly who I feel was treated pretty awfully by a succession of folk in his life. After I spoke at the G1MRA extravaganza last June I was contacted by John Mair who has a lovely Lowko guard's van with connections to Greenly. This article was originally published in the Bassett-Lowke society newsletter, and I am grateful for their permission to reproduce it here.*

THE FOLLOWING NOTES were prompted by Bob Chester-Lamb's short but interesting article "A Greenly at Titley Court?", which was published in Lowko News, Vol. 26, No. 2, May, 2016, page 9. Greenlys did indeed reside for several centuries at Titley Court, after which a Great Western Railway locomotive of the "Saint" class was named.\* The Greenly (originally "Greneleye") family, which can be traced back to at least the thirteenth century, had, however, by the nineteenth century become extremely ramified, and by no means all of its members belonged to the gentry or had the good fortune to live at the country seat of Titley Court, situated in a remote and idyllic area near the border between Herefordshire and Radnorshire.

A "G.W.R. Goods Brake Van" for Gauge 2 (Code Number 13414) was advertised in the Bassett-Lowke catalogue for 1911. (A reproduction of the advertisement appears on page 89 of the Bassett-Lowke "Re-introductory Catalogue" of 1968.) The van "is finished in their standard lead colour and lettered in white". On the van sides are printed, in capital letters, "G PADDINGTON W", and, in copper-plate writing, "Guard Greenly".



I had assumed that the latter inscription was a perhaps whimsical addition by Mr Bassett-Lowke (1877 – 1953) in honour of his contemporary,

collaborator and friend Henry Greenly (1876 – 1947). A reading of Greenly's biography, "The Miniature World of Henry Greenly" (King's Langley, 1973), by Ernest A. Steel and Elenora H. Steel (Henry's son-in-law and daughter respectively) has, however, caused me to revise my opinion.

Henry Greenly's father, Edwin Greenly (born in 1846) was a lifelong railwayman. He joined the Newport, Abergavenny and Hereford Railway in 1861, and subsequently became a goods, and then a passenger, guard on the Great Western Railway. At the time of Henry's birth, in 1876, Edwin was stationed in Merseyside (far from the Arcadian setting of Titley!), and later, in 1887, he was transferred to Westbourne Park, from where he worked on express passenger trains between Paddington and the West of England. Edwin Greenly's appearance, deportment and his respectful and attentive (but not obsequious) manner all commended him to the higher échelons of the Great Western Railway, a company which sedulously sought (and generally obtained) the approval of its first class passengers, especially those belonging to the gentry and to the aristocracy. Perhaps mindful of his own forebears, Edwin wryly remarked that he too had "been born to be a gentleman, but alas there was no vacancy".

The Steels observe that Edwin "was a pleasant, genial character, tolerant in outlook, a lover of good living". We learn too that he cared deeply for his family. Edwin Greenly seems to have been a thoroughly attractive human being, and it is pleasing to surmise that a willing Mr Bassett-Lowke may have been persuaded by Henry to agree to the inscription of his father's name upon the new model of the Great Western Railway Brake Van.



Note\*: The Bassett-Lowke Gauge 1 model of the G.W.R. locomotive "Titley Court" was, curiously and incorrectly, given the running number of 2936, which in real life belonged to another engine of the same class, named "Cefntilla Court" (a country house situated near Usk, in Monmouthshire). The number of the full size "Titley Court" was 2953.

## Engine portraits

Michael Wrottesley sometimes suggests that I should write up the H&TG1 talk as a book, and I am just vain enough to imagine that I might one day do so. To that end, I've started taking 'portraits' of fine engines so that if the day ever comes I have a decent stock of images whose copyright I own. Michael volunteered to be the first 'victim'. Here are a few of the results.



## Mike's GTG 2017



## AGM October 2017

Photographs by Robert Faulkner





## SURREY G1MRA GROUP

2018 fixture list as of March 6<sup>th</sup> 2018

**Surrey group meets second Tuesday afternoons**

**Please refer to your membership list for venues or email Adrian Johnstone as [a.johnstone@rhul.ac.uk](mailto:a.johnstone@rhul.ac.uk)**



Tue 9 Jan	Sutton MEC	13.00
Fri 19 Jan-Sun 21 Jan	London Model Engineer Show: Invicta Track at Alexandra Palace	
Tue 13 Feb	Ken Lowes	13.00
Sat 17 Feb	Bacon Butty Bash, Durrington; Salisbury and Stonehenge Track	
Sat 10 Mar	Oval at the Royal Holloway Science Festival; setup Friday from 16.00	
Sun 11 Mar	Sutton open afternoon: G1 running from 12.00	
Tue 13 Mar	Martin Hulse	13.30
Sun 18 Mar	GMES open afternoon: G1 running 14.00-17.00	
Sun 8 Apr	Sutton open afternoon: G1 running from 12.00	
Sun 15 Apr	GMES open afternoon: G1 running 14.00-17.00	
Tue 17 Apr	Michael Wrottesley	13.00 <b>Note: third Tuesday this month only!</b>
Sat 21 Apr	G1MRA Spring meeting; Shepshed	
Tue 8 May	Martin Hulse	13.00
Sun 13 May	Sutton open afternoon: G1 running from 12.00	
Sun 20 May	GMES open afternoon: G1 running 14.00-17.00	
Sat 26 May	Oval public run at Cranleigh Village Hall; setup from 08.00; public from 10.00	
Tue 12 Jun	Ken Lowes	13.00
Sun 10 Jun	Sutton open afternoon: G1 running from 12.00	
Sun 10 Jun	GMES open afternoon: G1 running 14.00-17.00	
Sat 23 Jun -Sun 24 Jun	Bluebell Model Railway Weekend	
Sun 8 Jul	Sutton open afternoon: G1 running from 12.00	
Sat 7 Jul -Sun 8 Jul	GMES rally	
Tue 10 Jul	Martin Hulse	13.00
Sun 29 Jul	GMES open afternoon: G1 running 14.00-17.00	
Sun 12 Aug	Sutton open afternoon: G1 running from 12.00	
Tue 14 Aug	Peter Jackman	13.00
Sat 18 Aug-Sun 19 Aug	Oval at Weald and Downland Museum Vintage Steam Weekend; Singleton	
Sun 19 Aug	GMES open afternoon: G1 running 14.00-17.00	
Sun 9 Sep	Sutton open afternoon: G1 running from 12.00	
Tue 11 Sep	Bob Boorman	13.00
Sun 16 Sep	GMES open afternoon: G1 running 14.00-17.00	
Tue 9 Oct	Guildford MES	13.00
TBC	Oval at the G1MRA AGM, Woking	
Sun 14 Oct	Sutton open afternoon: G1 running from 12.00	
Sun 21 Oct	GMES open afternoon: G1 running 14.00-17.00	
Sun 11 Nov	Sutton open afternoon: G1 running from 12.00	
Tue 13 Nov	Sutton MEC	13.00
Sat 24 Nov	TBC Oval public run at Dorking URC hall; setup from 08.00; public from 10.00	
Sun 9 Dec	Sutton open afternoon: G1 running from 12.00	
Sun 9 Dec	GMES open day: G1 running 11.00-15.00	
Tue 11 Dec	Bob Boorman	13.00